

BETRIEBSDRUCK
WORKING PRESSURE
PRESSION DE SERVICE } 2-10 BAR

BETRIEBSTEMPERATUR
WORKING TEMPERATURE
TEMPERATURE DE SERVICE } MAX. 100°C

TOLERANZEN
TOLERANCE
TOLERANCE } DIN ISO 2768-m

GEHAUSE GEGOSSEN
HOUSING CASTED
CORPS MOULE

GEGENFLANSCH, DICHTUNGEN UND SCHRAUBEN GEGOEREN ZUM LIEFERUMFANG (NUR DN65-100)
COUNTER FLANGES, GASKETS AND BOLTS BELONG TO DELIVERY (ONLY DN65-100)

FONT PARTIE DE LA FOURNITURE: CONTRE-BRIDES JOINTS ET LA BOULONNERIE UNIQUEMENT POUR DN 65-100

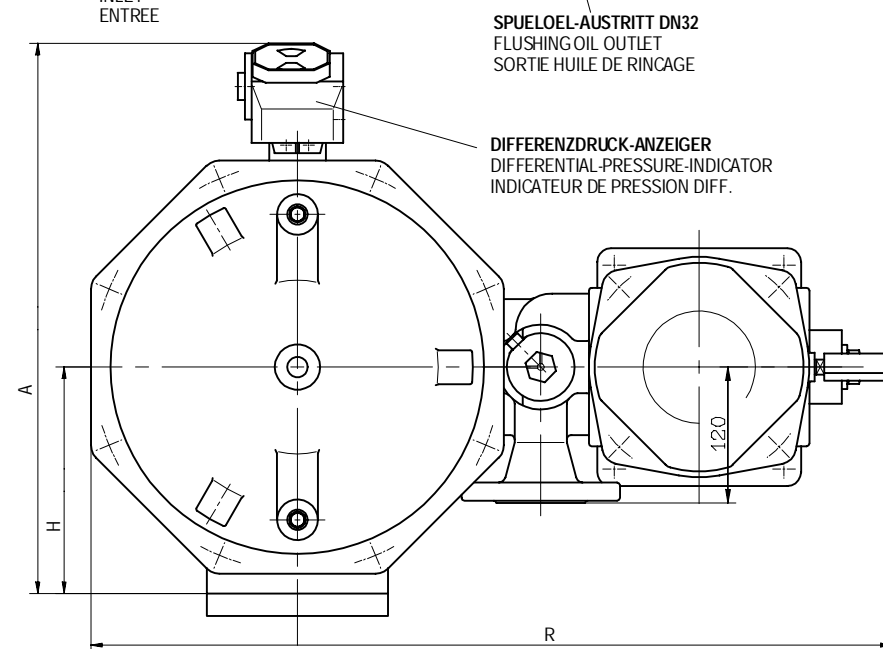

ANSCHLUSSFLANSCH F.DN125+150
CONNECTION FLANGES FOR DN125+150
BRIDES DESIREES POUR DN125+150 } DIN2501 PN 10

BODENBEFESTIGUNG
BOTTOM FASTENING
FIXATIONS AU SOL

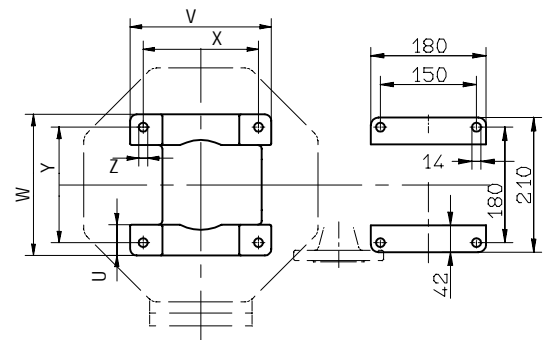

DN	A	B	C	D	E	F	G	H	øK	L	M	N	O	Q	R	S	T	U	V	W	X	Y	Z	GEWICHT KG
50	348	225	515	100	85	255	615	125	200	62	110	110	685	345	630	400	100	40	160	160	130	130	14	94
65	395	245	515	100	85	255	615	160	222	78	130	130	685	345	640	400	100	40	160	160	130	130	14	103
80	435	305	515	100	85	255	615	170	285	90	130	130	685	345	670	400	100	46	200	195	160	160	14	107
100	485	365	515	100	85	295	615	200	325	116	160	160	685	355	710	400	100	48	220	220	180	180	14	142
125	580	405	670	120	85	350	790	260	405	DIN2501 PN10			1000	380	755	600	550	58	270	270	220	220	14	
150	655	ø490	670	130	85	375	800	300	460	DIN2501 PN10			1000	395	810	600	550	58	330	310	290	260	18	

SUBJECT TO ALTERATIONS

AENDERUNGEN VORBEHALTEN

MODIFICATIONS RESERVEES

BACK FLUSHING FILTER
WITH RECYCLING UNIT

**VOLLAUTOM. RUECKSPUELFILTER MIT
SPUELOELAUFBEREITUNG TYP6.46.07**

FILTRE AUTOMATIQUE
AVEC FILTRE DE RECYCLAGE